

pulz[®]

sound matters



V5X V6L

Pulz V5X + V6L are a 3-way true line source system capable of high SPL and stunning clarity on and off axis in a compact format.

Pulz V5X mid high section consist of a 5" mid driver with a coaxially mounted compression driver loaded with a CAD optimised wave guide to form a true line source. A 6.5kHz. passive crossover seamlessly integrates the Mid and HF drivers for a near flat frequency response with minimum EQ.

The operating range of the V5X is optimised from 500 Hz. to 20kHz.

The system is designed for easy powering and deployment irrespective of the size and shape of the venue.

The V6L LF section is powered with 2 x 6.5" drivers with neodymium motor.

The box design of V6L and V5X are externally identical for visual compatibility and continuous rigging.

Critically designed and tuned V6L extends the low frequency capability of the system down to 65 Hz

The enclosures are built with 16mm marine grade Birch Plywood.

The speakers can be flown or ground stacked with the provided rigging accessories.

Each box can be tilted individually from 0 degree to 15 degrees with 1 degree increments to achieve precise vertical coverage. SpeakON connection on the rear plate ensures secure and fast connectivity between the boxes.

Upto four V5X or V6L boxes can be powered by a single channel of a high power amplifier, making the system easy to wire and deploy efficiently.

Pulz V5X + V6L is designed taking into considerations all the practical aspects of line source deployment yet not compromising on the ultimate sonic quality and long term consistent reliable performance.

FEATURES

- 5" (125 mm) coaxial driver
- 2 x 6.5" (165 mm) Low-Mid Driver
- High performance and very high SPL
- Wide horizontal dispersion and variable vertical dispersion
- Configurable array length depending on the distance to be covered
- Very low SPL gradient from front to back
- Compact design and easy installation

SPECIFICATION

V5X

Frequency Response 500Hz to 20kHz

Maximum Input Power 80W AES, 320W peak

Sensitivity 93dB @ 1W/1m

Maximum SPL 112dB continuous, 118dB peak @1m

Nominal Impedance 16 Ω

Mid Frequency Driver 5" (125 mm) Mid Frequency driver with coaxial entry

High Frequency Driver 0.63" (44 mm) voice coil compression driver mounted coaxially

Recommended Filter 500Hz 24dB/octave Linkwitz high pass filter; 20kHz 12dB/octave Butterworth low pass filter

Crossover 6kHz Passive, low loss air core inductors and MKP capacitors

Nominal Dispersion 100 °H x 10 °V

Finish Black scratch resistant structured paint

Connector 2 X Speakon

Enclosure Sealed type, 16 mm Birch Plywood

Grill Acoustically transparent perforated steel with foam backing

Dimensions (H x W x D) 208mm x 500mm x 371mm (8.2" x 19.7" x 14.6")

Net Weight 14.6 kg (32.2 lbs)

Packed Weight 17.5 kg (38.6 lbs)

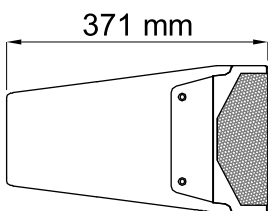

SIDE VIEW



FRONT VIEW

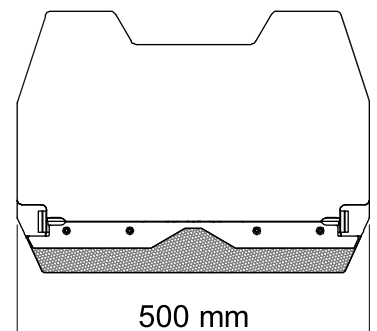

TOP VIEW

Pulz Electronics Ltd,
Plot 10A, Kailashpati,
Veera Desai Road, Andheri (W)
Mumbai - 400 053 India,
Tel: 022 49702172
E-mail: mumbai@pulz.co.in
www.pulz.co.in



FEATURES

- 5" (125 mm) coaxial driver
- 2 x 6.5" (165 mm) Low-Mid Driver
- High performance and very high SPL
- Wide horizontal dispersion and variable vertical dispersion
- Configurable array length depending on the distance to be covered
- Very low SPL gradient from front to back
- Compact design and easy installation

SPECIFICATION

V6L

Frequency Response 50Hz to 800Hz

Maximum Input Power 400W AES, 1600W peak

Sensitivity 95dB @ 1V/1m

Maximum SPL 121dB continuous, 127dB peak @1m

Nominal Impedance 16 Ω

Low — Mid Frequency Driver 2 x 6.5" (165mm) Low - Mid driver

Recommended Filter 50Hz 18dB/octave Butterworth high pass filter; 600Hz 24dB/octave Linkwitz Riley low pass filter

Crossover 6kHz Passive, low loss air core inductors and MKP capacitors

Nominal Dispersion 100° H x 10° V

Finish Black scratch resistant structured paint

Connector 2 X Speakon

Enclosure Bass reflex type, 16 mm Birch Plywood

Grill Acoustically transparent perforated steel with foam backing

Dimensions (H x W x D) 208mm x 500mm x 371mm (8.2" x 19.7" x 14.6")

Net Weight 14kg (30.9 lbs)

Packed Weight 17kg (37.5 lbs)

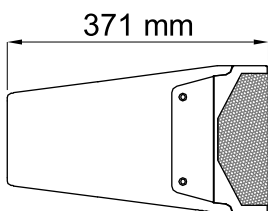

SIDE VIEW



FRONT VIEW

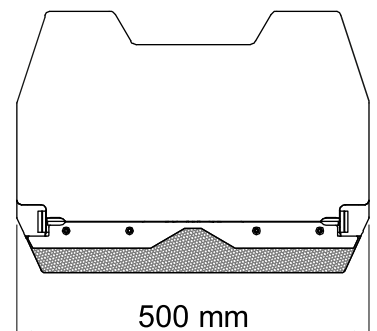

TOP VIEW

Pulz Electronics Ltd,
Plot 10A, Kailashpati,
Veera Desai Road, Andheri (W)
Mumbai - 400 053 India,
Tel: 022 49702172
E-mail: mumbai@pulz.co.in
www.pulz.co.in

